

# Keysight 8766/7/8/9K

## Microwave Single-Pole Multi-Throw Switches

Technical Overview

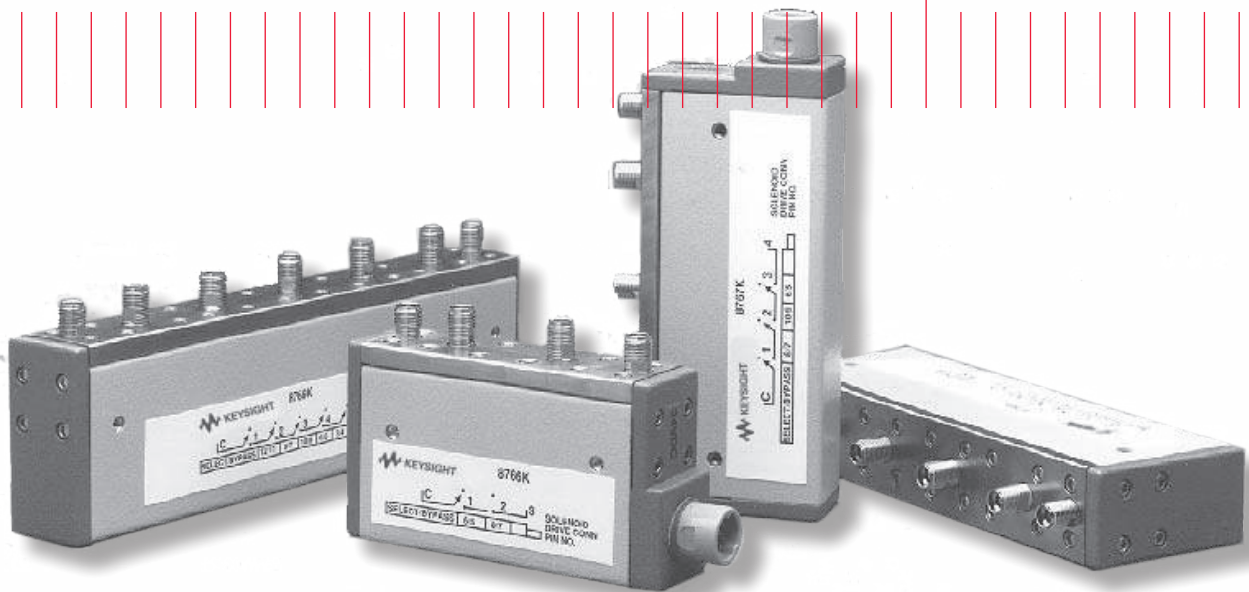

# Introduction

## Features and description

- Exceptional reliability, long life (5,000,000 cycles minimum)
- Excellent repeatability
- Compact
- Easy GPIB implementation for ATE applications
- Single-pole, multiple-throw models available:
  - three-throw (8766K)
  - four-throw (8767K)
  - five-throw (8768K)
  - six-throw (8769K)

This Keysight Technologies, Inc. family of single-pole, multiple-throw switches utilizes the same proven technology as the well known Keysight 849X family of step attenuators. These products offer the same rugged reliability, excellent repeatability (typically 0.01 dB to 18 GHz and 0.05 dB to 26.5 GHz), long life (greater than 5 million switching cycles), compactness, and broadband performance as the 849X family. Each product consists of 2 to 5 solenoid driven switching sections connected in series. The solenoid armatures are held in place with permanent magnets able to withstand shocks over 10 g's.

The sections switch within 20 milliseconds, including contact settling time, which is of importance for automatic test applications. The switches include self-interrupting contacts which minimize power consumption and simplify the driver circuit design (figure 1). Each model is available with a wide range of solenoid voltage choices (24 volts, standard, or optionally 5 or 15 volts) to match your product or system's requirements.

## Section switching

Figure 1 shows one switching section schematic. Each section utilizes one solenoid with dual coil windings, one coil to switch in the RF connector, and one coil to switch in the thru line.

With a positive voltage applied to the common pin, the state (RF connector or thru line) of a particular section is determined by connecting its RF connector pin or thru pin to a negative voltage or ground. Tables 1 through 4 define the pin assignments for the different switches.

As a section is switched, the internal contacts of the activated coil open, thus shutting off current flow. At the same time, the internal contacts for the other coil close so that it can be activated when desired. Figure 1 shows a section that has been switched to the RF connector position (note the closed thru line coil contact). The switching is "break-before-make" type, thus a momentary interruption of the RF signal occurs at switching.

Although all sections can be switched simultaneously, the attenuator drive must not allow both pins of the same section (e.g., section 1, pins 5 and 6) to be activated concurrently, or else that section would cycle rapidly. All terminals are "floating," so bipolar or unipolar power supplies may be used.

## Typical driver circuit

Figure 1 shows an economical TTL compatible driver circuit for a single switching section utilizing an IC relay driver and an inverter. A TTL "HI" input to the driver switches in the RF connector, while a "LO" will activate the thru line for that section. This provides a complementary driver for the section which assures that only one solenoid of the pair is activated at a time. Diode protection is required to protect the IC from the solenoid voltage flyback.

Switch position can be indicated remotely by utilizing the open and closed states of the internal coil contacts. Figure 1 displays two indicator circuits, one providing a TTL output and one that activates an LED. These circuits will output a TTL "HI" (LED lamp "ON") if the RF connector is in the RF circuit, and will output a TTL "LO" (LED lamp "OFF") if the thru line is in the RF circuit. Since current is drawn through the coil for these circuits, inadvertent switching is prevented by limiting the current to 5 mA.

Keysight assumes no responsibility for the use of any circuits described herein and makes no representation or warranties, express or implied, that such circuits are free from patent infringement.

## GPIB attenuator/switch driver

Employing programmable Keysight step attenuators and switches in an automatic test system becomes an easy task when the Keysight 11713A or 87130A attenuator/switch driver is specified into the system. The 11713A has all of the necessary features to provide GPIB control of up to ten switching sections of the 8766/7/8/9 series switches (e.g., five 8766s, two 8769s, etc.).

The 11713A includes an integral power supply (with short circuit protection) that can simultaneously provide 125 milliamps at 24 volts to all contacts for control of the attenuators and switches, so no external power supply is needed. Each 11713A is provided with two (2) plug-in drive cables for the programmable switches to simplify connection to the driver.

The 11713A also features convenient front panel keys so the user can manually activate the individual switch sections when in the "local" mode. Switching time for the drivers is less than 10 milliseconds.

The 87130A is a 3.5 inch high, full width system II attenuator/switch driver capable of driving up to 248 bistatic electromechanical switches or attenuator sections. The 87130A is controlled over GPIB via standard commands for programmable instruments (SCPI) commands. The 87130A has been designed for use in both ATE switching systems and computer controlled bench top applications.

More configuration details are available on the Keysight 11713A and 87130A in literature number 5963-2038E.

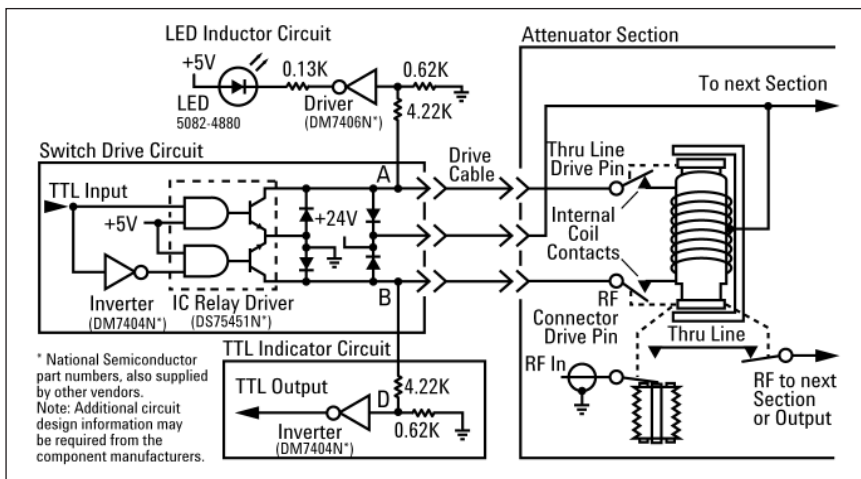

Figure 1

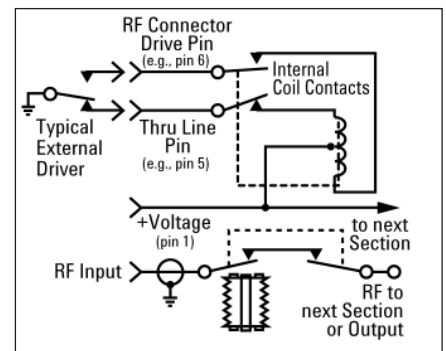

Figure 2

# Isolation and insertion loss

Isolation and insertion loss vary with frequency and depend on the port selected, as shown in the chart and tables below. The input connector "C" is always defined as the connector at the opposite end of the switch from the dc drive cable.

The output ports are numbered sequentially from the input connector. For example, if an 8768K is being used, use the 8768K table to read isolation to each port. If port three (the third connector from the input) is selected, the isolation to ports 1 and 2 will follow curve A. Isolation to port 4 will follow curve B and isolation to port 5 will follow curve C. Reading from Figure 3 at 8 GHz, the worst case isolation to ports 1 and 2 will be 30 dB; to port 4, 45 dB; and to port 5, 65 dB. Note that in selecting ports 1 or 2, isolation to disconnected ports can be varied by choosing the position of each section to "thru" or "on." The important thing to note is that, depending on the user's application, port assignments can be important to optimize performance at higher frequencies.

All isolation tables refer to Figure 3.

# Specifications

**Frequency range:** dc to 26.5 GHz all models or dc to 18 GHz for Option 876xK-002 (SMA connectors)

Maximum SW				
Frequency (GHz):	dc to 8	8 to 12.4	12.4 to 18	18 to 26.5
8766/7/8K	1.3	1.5	1.6	1.8
8769K	1.3	1.55	1.8	2.05

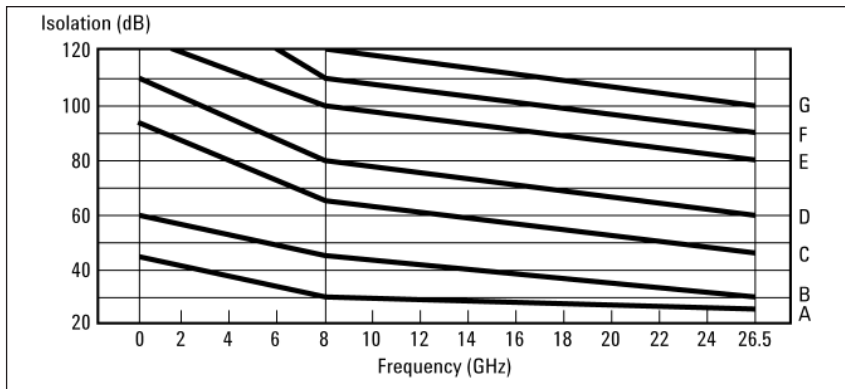

Figure 3. Isolation curves

Table 1. Keysight 8766K with switch profile and connector and pin assignments

Port selected	X = Activated viking cable pin/wire # and color of ribbon pin # ( )		Section status		Isolation curve (see table 3) for port #		
	Section 1	Section 2	1	2	1	2	3
	6 (2) YEL Conn.	5 (13) VIO Thru	8 (5) GRN Conn.	7 (11) VLK Thru			
1	X	X	On	On	-	B	D
	X		On	Off	-	C	B
2		X	Off	On	A	-	B
3		X	Off	Off	A	A	-

Note: Red wire, pin(1) of viking cable, or brown wire, pin(6) of ribbon cable must be connected to + 24 voc.

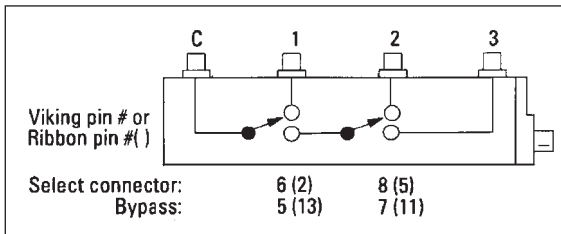
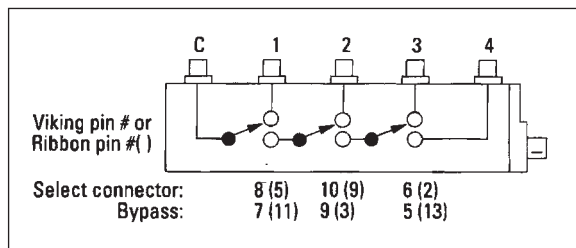

Table 2. Keysight 8767K with switch profile and connector and pin assignments

Port selected	X = Activated viking cable pin/wire # and color or ribbon pin # ( )						Section status			Isolation curve (see table 3) for port #				
	Section 1	Section 2	Section 3	Section 4	Section 5	Section 6	1	2	3	1	2	3	4	
	8 (5) GRN Conn.	7 (11) BLK Thru	10 (9) BLU Conn.	9 (3) ORN Thru	6 (2) YEL Conn.	5 (13) V/O Thru								
1	X		X		X		On	On	On	-	B	D	E	
	X		X			X	On	On	Off	-	B	E	D	
	X			X	X		On	Off	On	-	C	B	C	
	X			X		X	On	Off	Off	-	C	C	B	
2		X	X		X		Off	On	On	A	-	B	C	
		X	X			X	Off	On	Off	A	-	C	B	
3		X		X	X		Off	Off	On	A	A	-	A	
4		X		X		X	Off	Off	Off	A	A	A	-	



Note: Red wire, pin(1) of viking cable, or brown wire, pin(6) of ribbon cable must be connected to + 24 voc

Table 3. Keysight 8768K with switch profile and connector and pin assignments

Port selected	X = Activated viking cable pin/wire # and color or ribbon pin # ( )								Section status				Isolation curve for port #				
	Section 1	Section 2	Section 3	Section 4	Section 5	Section 6	Section 7	Section 8	1	2	3	4	1	2	3	4	5
	12 (10) WHT Conn.	11 (4) BRN Thru	8 (5) GRN Conn.	7 (11) BLK Thru	10 (9) BLU Conn.	9 (3) ORN Thru	6 (2) YEL Conn.	5 (13) V/O Thru									
1	X		X		X		X		On	On	On	On	-	B	D	E	F
	X		X			X	X		On	On	Off	On	-	B	E	D	E
	X			X	X		X		On	Off	On	On	-	C	B	D	E
	X			X		X	X		On	Off	Off	On	-	C	C	B	C
2		X	X		X		X		Off	On	On	On	A	-	B	D	E
		X	X			X	X		Off	On	Off	On	A	-	C	B	C
3		X		X	X		X		Off	Off	On	On	A	A	-	B	C
4		X		X		X	X		Off	Off	Off	On	A	A	A	-	A
5		X		X		X		X	Off	Off	Off	Off	A	A	A	A	-

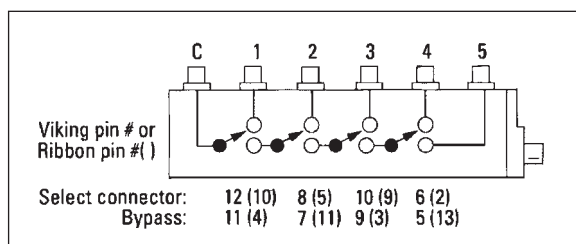

Note: Red wire, pin(1) of viking cable, or brown wire, pin(6) of ribbon cable must be connected to + 24 voc.

Table 4. Keysight 8769K with switch profile and connector and pin assignments

Port selected	X = Activated viking cable pin/wire # and color or ribbon pin # ( )										Section status						Isolation curve for port #					
	Section 1	Section 2	Section 3	Section 4	Section 5	1	2	3	4	5	1	2	3	4	5	6						
	12 (10) WHT Conn. Thru	11 (4) BRN Conn. Thru	8 (5) GRN (11) BLK Conn. Thru	7	10 (9) BLU Conn. Thru	9 (3) ORN Thru	6 (2) YEL Conn. Thru	5 (13) VIO Thru	3 (8) GRY Conn. Thru	4 (7) WT/ RD Thru												
1	X	X		X	X		X	X		X	On	On	On	On	On	- B D E F G						
	X	X		X			X	X			On	On	On	Off	On	- B D F E F						
	X	X			X	X		X			On	On	Off	On	On	- B E D E F						
	X		X	X		X		X			On	Off	On	On	On	- C B D E F						
	X		X		X	X		X			On	Off	Off	On	On	- C C B C E						
	X		X		X		X	X			On	Off	Off	Off	On	- C C C B D						
	X		X		X		X		X		On	Off	Off	Off	Off	- C C C C B						
2		X	X	X		X		X			Off	On	On	On	On	A - B D E E						
		X	X		X	X		X			Off	On	Off	On	On	A - C B C F						
		X	X		X		X		X		Off	On	Off	Off	Off	A - C C C B						
3		X	X	X		X		X			Off	Off	On	On	On	A A - B C E						
		X	X	X			X	X			Off	Off	On	Off	On	A A - A B D						
		X	X	X			X		X		Off	Off	On	Off	Off	A A - C C A						
4		X	X		X	X		X			Off	Off	Off	On	On	A A A - A C						
5		X	X		X		X	X			Off	Off	Off	Off	On	A A A A - B						
6		X	X		X		X		X		Off	Off	Off	Off	Off	A A A A A -						

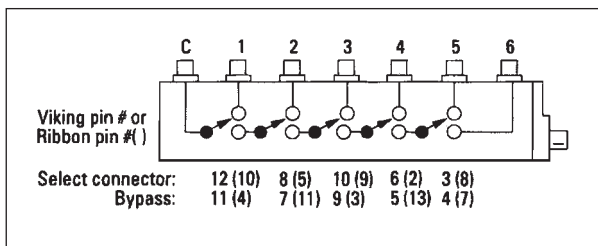

Note: Red wire, pin(1) of viking cable, or brown wire, pin(6) of ribbon cable must be connected to + 24 voc.

## Specifications, cont.

### Maximum insertion loss

<b>Port 1</b>	0.2 dB +0.05 dB/GHz
<b>Port 2</b>	0.2 dB +0.06 dB/GHz
<b>Port 3</b>	0.2 dB +0.08 dB/GHz
<b>Port 4</b>	0.25 dB +0.095 dB/GHz
<b>Port 5</b>	0.25 dB +0.108 dB/GHz
<b>Port 6</b>	0.25 dB +0.12 dB/GHz

### RF input power (max):

1 watt average, 100 watts peak  
(10 •s pulse width)

### Life (min):

5 million cycles per section

### Repeatability:

0.01 dB, typ. to 18 GHz, 0.05 dB, typ. to  
26.5 GHz (up to 5,000,000 cycles)

## Environmental capabilities

### Temperature, operating:

–20°C to +75°C

### Temperature, non-operating:

–55°C to +85°C

### Altitude, operating:

15,000 ft (4,570 meters)

### Altitude, non-operating:

50,000 ft (13,700 meters)

### Humidity:

Cycling 5 days, 40°C at 95% RH with  
condensation

### Shock, operating:

10 g's, 6 ms, on six sides, three blows

### Shock, non-operating:

500 g's, 1.8 ms, in six directions

### Vibration, operating:

5 g's, 34 to 2000 Hz

### EMC:

Radiated interference is within the require-  
ments of MIL-STD-461B method RE02, VDE  
0871, and CTSPR Publication 11.

## Ordering information

### Microwave single-pole multi-throw switches

8766K	Single-pole, three-throw
8767K	Single-pole, four-throw
8768K	Single-pole, five-throw
8769K	Single-pole, six-throw

## Options

To add options to a product, use the  
following scheme:

Model: 876xK (x = 6, 7, 8, 9)

Model options: 876xK-Option 001

876xK-Option 002

### Supply voltage (must choose one)

876xK-011	5 V solenoid
876xK-015	15 V solenoid
876xK-024	24 V solenoid (standard option)

### RF connectors (must choose one)

876xK-002	SMA female connectors
876xK-004	3.5 mm female (standard option)

### DC connectors (must choose one)

876xK-016	16 inch ribbon cable
876xK-060	5 foot dc control cable; 12 pin "viking" (standard option)

### Calibration documentation (optional)

876xK-UK6	SWR and insertion loss data measured with an automatic network analyzer with very small uncertainties; directly traceable to NIST standards. Calibration frequencies: 1.5 to 26.5 GHz, every 0.25 GHz.
-----------	--

Other combinations can be created for your  
applications; refer to Keysight Application  
Note 5954-8892, "Switching, Novel  
Combinations of Microwave Switches  
and Step Attenuators for Programming  
Applications."

## Mechanical information

Net weight:	8766K	8767K	8768K	8769K
	178 grams (6.3 oz)	235 grams (8.3 oz)	292 grams (10.3 oz)	349 grams (12.3 oz)

**Mounting position:** For any orientation, holes are threaded for a metric screw (m 3 x 0.5 x 5.1 deep).A

**RF connectors:** 3.5 mm female (SMA compatible)  
Option 876xK-002 SMA (for use only to 18 GHz)

**Switching speed:** Maximum 20 msec including settling time

Solenoids	Coil voltage	Switching current <sup>B</sup>	Nominal coil impedance
Standard	24 V (20 to 30 V)	130 mA (at 24 V)	185 Ohms
Option 876xK-015	15 V (13 to 22 V)	187 mA (at 15 V)	80 Ohms
Option 876xK-011	5 V (4 to 7 V)	332 mA (at 5 V)	17 Ohms

B. Current per section; approximately 8 msec duration before internal contacts open the coil circuit.

Accessory provided (except Option 008 and 016): Solenoid drive plug on 5-foot cable included. (Replacement plug and cable assembly available as part number 8120-2178, except 8769K p/n 5061-0969.)

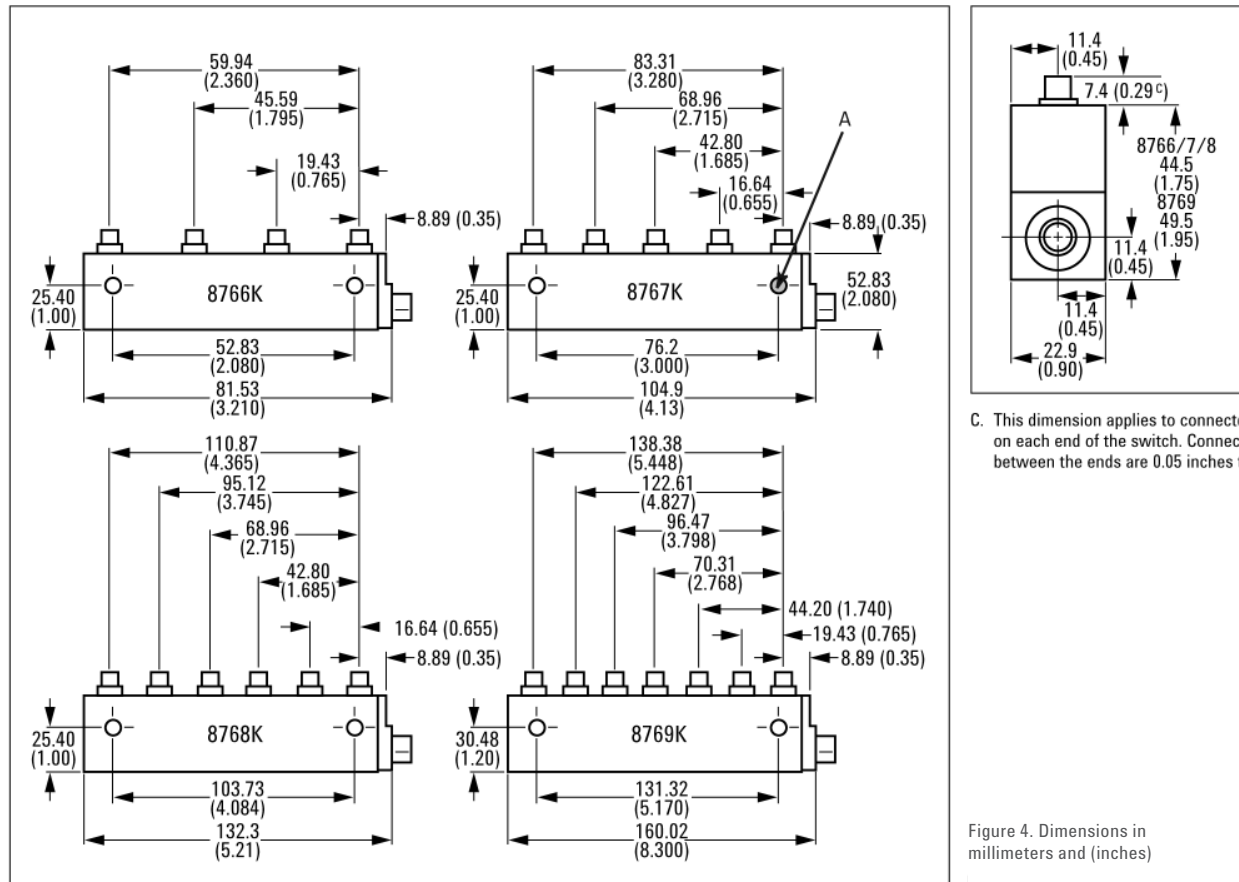

C. This dimension applies to connectors on each end of the switch. Connector: between the ends are 0.05 inches tall

Figure 4. Dimensions in millimeters and (inches)



**myKeysight**

**myKeysight**

[www.keysight.com/find/mykeysight](http://www.keysight.com/find/mykeysight)

A personalized view into the information most relevant to you.

**Three-Year Warranty**

[www.keysight.com/find/ThreeYearWarranty](http://www.keysight.com/find/ThreeYearWarranty)

Keysight's commitment to superior product quality and lower total cost of ownership. The only test and measurement company with three-year warranty standard on all instruments, worldwide.



**Keysight Assurance Plans**

[www.keysight.com/find/AssurancePlans](http://www.keysight.com/find/AssurancePlans)

Up to five years of protection and no budgetary surprises to ensure your instruments are operating to specification so you can rely on accurate measurements.



[www.keysight.com/quality](http://www.keysight.com/quality)

Keysight Technologies, Inc.  
DEKRA Certified ISO 9001:2008  
Quality Management System



**Keysight Channel Partners**

[www.keysight.com/find/channelpartners](http://www.keysight.com/find/channelpartners)

Get the best of both worlds: Keysight's measurement expertise and product breadth, combined with channel partner convenience.

**ATCA**®, **AdvancedTCA**®, and the **ATCA logo** are registered US trademarks of the PCI Industrial Computer Manufacturers Group.

For more information on Keysight Technologies' products, applications or services, please contact your local Keysight office. The complete list is available at: [www.keysight.com/find/contactus](http://www.keysight.com/find/contactus)

**Americas**

Canada	(877) 894 4414
Brazil	55 11 3351 7010
Mexico	001 800 254 2440
United States	(800) 829 4444

**Asia Pacific**

Australia	1 800 629 485
China	800 810 0189
Hong Kong	800 938 693
India	1 800 112 929
Japan	0120 (421) 345
Korea	080 769 0800
Malaysia	1 800 888 848
Singapore	1 800 375 8100
Taiwan	0800 047 866
Other AP Countries	(65) 6375 8100

**Europe & Middle East**

Austria	0800 001122
Belgium	0800 58580
Finland	0800 523252
France	0805 980333
Germany	0800 6270999
Ireland	1800 832700
Israel	1 809 343051
Italy	800 599100
Luxembourg	+32 800 58580
Netherlands	0800 0233200
Russia	8800 5009286
Spain	0800 000154
Sweden	0200 882255
Switzerland	0800 805353
	Opt. 1 (DE)
	Opt. 2 (FR)
	Opt. 3 (IT)
United Kingdom	0800 0260637

For other unlisted countries:  
[www.keysight.com/find/contactus](http://www.keysight.com/find/contactus)  
(BP-07-10-14)